

Section cut B-B  
Scale: 1:5

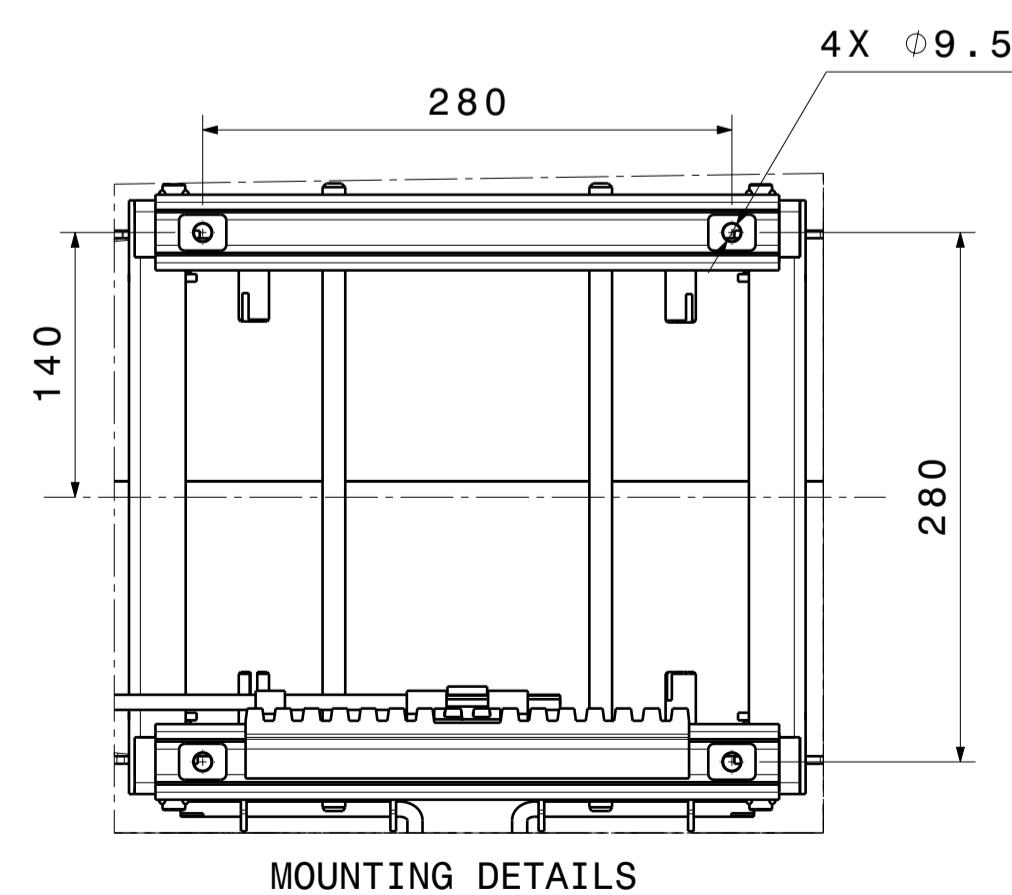

NOTE:

- GENERAL TOLERANCE ON FOAM  $\pm 10$ .
- GENERAL TOLERANCE ON SHEET METAL PARTS  $\pm 2$ .
- SURFACE TREATMENT OF METAL PARTS:  
POWDER COATING 50  $\mu$  DFT - SS 7651 - IS REQUIRED.
- SEATBASE & BACKREST TO BE COVERED WITH THICK POLYTHENE BAG.
- CUSHION FOR SEATBASE AND BACKREST TO BE FIRE RETARDANT AND MOULDED IN P.U FOAM.
- FIRE RETARDANT MATERIALS SHOULD CONFORM IS:15061
- UPHOLSTERY MATERIAL : FOAM LAMINATED FABRIC QUALITY : 3035 A 008ma.
- SEAT TO CONFIRM AIS-023 STANDARD.
- CONTROL KNOB / LEVER OPERATING FORCES:  
A) RECLINING LEVER : 5KGF (MAX)  
B) FORE AND AFT LEVER : 5KGF (MAX)  
C) HEAD REST ADJUSTMENT : 5KGF (MAX)
- PARTS TO BE SUPPLIED AS PER APPROVED SAMPLE.
- HEAD REST ADJUSTMENT TRAVEL = 60 MM

S. NO.	MOD. No.	DATE	ZONE	MODIFICATION	D.O.	STDZ.

INFORMATION GIVEN IN THIS DRG IS THE SOLE PROPERTY OF CVG SEATING (INDIA) PVT.LTD. IT SHOULD NOT BE COPIED OR COMMUNICATED TO OTHERS WITHOUT THE WRITTEN APPROVAL FROM CVG SEATING (INDIA) PVT.LTD.

ALL DIMENSIONS ARE IN MM. NO SHARP CORNERS OR BURRS ALLOWED				SIGN	DATE
MATL. SPEC.	NA	DRN	K.D.	12-12-19	
FINISH:	xxxxxxx	CHD.	Y.B.	12-12-19	
WEIGHT (CALC):	15 Kg	DO NOT SCALE		APPD.	
<b>CVG</b> CVG SEATING (INDIA) PVT. LTD.		BASKA - 389 350, GUJARAT			
CRITICAL CHARACTERISTIC	SCALE 1:2	SIZE A1	USED ON	SOURCE	
DESCRIPTION <b>TRUCK DRIVER SEAT D2 WITH HT RISER &amp; SLIDERAIL</b>			DRG No.	MOD	
SHEET 1 OF 1			X		